

# ATSystem

AUTO-TRACKING SPECTROPHOTOMETER



Scanning Instrument Manual







Dear Customer:

Congratulations! We at X-Rite, Incorporated are proud to present you with an Auto-Tracking Spectrophotometer. This system represents the very latest in microcontrollers, integrated circuits, optics, and software design. As a result, your ATSystem is a rugged and reliable instrument whose performance and design are not surpassed.

To fully appreciate and protect your investment, we suggest that you take the necessary time to read and fully understand this manual. As always, X-Rite stands behind your system with a three-year limited warranty, and a dedicated service organization. If the need arises, please don't hesitate to call us.

Thank you for your trust and confidence.

X-Rite, Incorporated



# User Information

---

## **FCC**

This equipment has been tested and found to comply with the limits for a Class A digital device, pursuant to Part 15 of the FCC Rules. These limits are designed to provide reasonable protection against harmful interference when the equipment is operated in a commercial environment. This equipment generates, uses, and can radiate radio frequency energy and, if not installed and used in accordance with the instruction manual, may cause harmful interference to radio communications.

Operation of this equipment in a residential area is likely to cause harmful interference in which case the user will be required to correct the interference at his own expense.

## **Canada**

This Class A digital apparatus meets all requirements of the Canadian Interference-Causing Equipment Regulations.

Cet appareil numérique de la classe A respecte toutes les exigences du Règlement sur le matériel brouilleur du Canada.

**NOTE:** Shielded interface cables must be used in order to maintain compliance with the desired FCC and European emission requirements.

Keep Cal Plaques Clean At All Times.

Kalibrierstandards sauberhalten!

Siempre mantenga la placa de calibración limpia.

Tenir le plaque de calibration propre tout le temps.

Sempre mantenga la placca della calibrazione pulita.

Do Not Oil Moving Parts.

Bewegliche Teile nicht ölen!

No lubrifique las peizas en movimiento

Ne pas lubrifier les pièces en mouvement

Non lubrificare le parti mobili.

## INTRODUCTION

**CAUTION:** Use only the 24v Adapter (P/N ATS40-109) to supply power to the Docking Station.  
**WARNUNG:** Benutzen Sie nur das X-Rite 24 V Netzteil P/N ATS40-109 für die Docking Station.  
**ADVERTENCIA:** Use solamente el Adaptador de 24v (pieza N° ATS40-109) para suministrar la energía al mecanismo de conexión.  
**AVERTISSEMENT:** Utiliser seulement l'adaptateur de 24v (P/N ATS40-109) pour fournir l'alimentation au mécanisme de connexion.  
**AVVERTIMENTO:** Usare solamente l'adattatore di 24v (parte n. ATS40-109) per fornire l'alimentazione al meccanismo del collegamento.

**CAUTION:** Use only the 12v Adapter (P/N SE30-77) to supply power to the Handheld Instrument.  
**WARNUNG:** Benutzen Sie nur das X-Rite 12 V Netzteil P/N SE30-77 für das tragbare Messgerät.  
**ADVERTENCIA:** Use solamente el Adaptador de 12v (pieza N° SE30-77) para suministrar la energía al instrumento portátil.  
**AVERTISSEMENT:** Utiliser seulement l'adaptateur de 12v (P/N SE30-77) pour fournir l'alimentation au instrument portable.  
**AVVERTIMENTO:** Usare solamente l'adattatore di 12v (parte n. SE30-77) per fornire l'alimentazione allo strumento portatile.

The Manufacturer: **X-Rite, Incorporated**  
Der Hersteller: **3100 44th Street, S.W.**  
El fabricante: **Grandville, Michigan 49418**  
Le fabricant:  
Il fabbricante:  
  
Declares that: **Auto Tracking Spectrophotometer**  
gibt bekannt, dass: **ATS**  
advierte que:  
avertit que:  
avverte che:

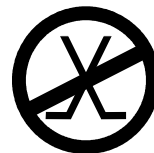

is not intended to be connected to a public telecommunications network.  
an ein öffentliches Telekommunikations-Netzwerk nicht angeschlossen werden soll.  
no debe ser conectado a redes de telecomunicaciones públicas.  
ne doit pas être relié à un réseau de télécommunication publique.  
non deve essere connesso a reti di telecomunicazioni pubblici.

**CE DECLARATION**

Manufacturer's Name: X-Rite, Incorporated  
Manufacturer's Address: 3100 44<sup>th</sup> Street, S.W.  
Grandville, Michigan 49418  
U.S.A.

Model Name: Auto Tracking Spectrophotometer  
Model No.: ATS

Directive(s) Conformance: EMC 89/336/EEC LVD 73/23/EEC

As of August 13, 2005, X-Rite products meet the European Union – Waste Electrical and Electronic Equipment (WEEE) directive. Please refer to [www.xrite.com](http://www.xrite.com) for more information on X-Rite's compliance with the WEEE directive.

## **PROPRIETARY NOTICE**

The information contained in this manual is derived from patent and proprietary data of X-Rite, Incorporated. This manual has been prepared solely for the purpose of assisting in the use and general maintenance of this instrument.

The contents of this manual are the property of X-Rite, Incorporated and are copyrighted. Publication of this information does not imply any rights to reproduce or use this manual for any purpose other than installing, operating, or maintaining this instrument. No part of this manual may be reproduced, transcribed, transmitted, stored in a retrieval system, or translated into any language or computer language, in any form or by any means, electronic, magnetic, mechanical, optical, manual, or otherwise, without the prior written permission of an officer of X-Rite, Incorporated.

This instrument is covered by U.S. patent #6,002,488 and patents pending. Foreign patent numbers provided on request.

**Copyright © 2005 by X-Rite, Incorporated**

**“ALL RIGHTS RESERVED”**



## **LIMITED WARRANTY**

X-Rite, Incorporated warrants each unit manufactured to be free of defects in material and workmanship for a period of thirty six months. If the fault has been caused by misuse or abnormal conditions of operation, repairs will be billed at a nominal cost. In this case, an estimate will be submitted before work is started, if requested.

**There are no warranties of merchantability or fitness. This warranty obligation is limited to servicing the unit returned to X-Rite, Incorporated for that purpose.**

Always include serial number in any correspondence concerning the unit. The serial number is located on the back of the instrument.

This agreement shall be interpreted in accordance with the laws of the State of Michigan and jurisdiction and venue shall lie with the courts of Michigan as selected by X-Rite, Incorporated.

## **INSTRUMENT TRACEABILITY**

The spectral reflectance values for the supplied white reference are traceable to the National Institute of Standards and Technology through the RIT Munsell Color Laboratory. The RIT Laboratory maintains standards to which NIST assigned values. These standards were used in assigning values to X-Rite's two primary standard white porcelain on steel plaques.

A calibration report (MCSL-18) issued by Munsell Color Science Laboratory contains measurement methods, measurement values, and verifies the ceramic plaques' NIST traceability path. These two plaques are used to generate the supplied white reference.

## **ABOUT THIS MANUAL**

This document covers the installation, operation, calibration, and general maintenance of your ATSystem. Refer to your ATSystem Getting Started Software Manual for software installation instructions.

This manual is organized into five sections and two appendices. In order to make the best use of your system, it is recommended that you read all sections and appendices.

# Table of Contents

---

## **SECTION ONE—Installing the System**

Unpacking and Inspection .....	1-1
Packaging Drawing and Parts List.....	1-1
System Description.....	1-2
Track and Docking Station.....	1-3
ATS Scanning Head .....	1-4
Handheld Spectrodensitometer .....	1-4
Vacuum Pump.....	1-5
Installing the ATS Scanning Head.....	1-6
System Connections.....	1-7
Vacuum Pump Connections .....	1-7
Serial Port Interface Connection .....	1-8
Handheld Spectrodensitometer Connection.....	1-9
Connecting Power.....	1-9

## **SECTION TWO—Operating the System**

Sheet Loading and Alignment .....	2-1
Track Positioning .....	2-2
Performing a Recognition/Measurement on the Scanning Instrument.....	2-3
Taking a Measurement with the Handheld Instrument .....	2-4

## **SECTION THREE—Calibration**

Calibrating the Scanning Instrument .....	3-1
Calibrating the Handheld Instrument.....	3-2
Cleaning the Handheld Calibration Reference .....	3-2

<b>SECTION FOUR—General Maintenance</b>	
Repair Information .....	4-1
Overview.....	4-1
Scanning Head .....	4-1
Cleaning (1 to 2 times a month).....	4-1
Maintenance.....	4-3
Scanning Track.....	4-3
Cleaning (1 to 2 times a month).....	4-3
Maintenance.....	4-3
Cleaning the Scanning Head Calibration Disks .....	4-4
<b>SECTION FIVE—Troubleshooting Tips</b>	5-1
<b>APPENDIX A—Technical Specifications</b>	A-1
<b>APPENDIX B—Parts List and Packaging Drawing</b>	B-1

# Installing the System

---

This section covers unpacking, inspection, and installation of your system. System description and vocabulary illustrations are also included. You should read through this entire section to familiarize yourself with your instrument.

## Section Contents

- Unpacking and Inspection..... 1-1
- System Description ..... 1-2
- Installing the ATS Scanning Head ... 1-6
- System Connections ..... 1-7

## UNPACKING AND INSPECTION

The main system components are packaged separately:

- Track/Docking Station, Handheld Instrument, Cabling, Software and Accessories
- Vacuum Pump

After removing the components from each shipping carton, inspect them for damage. If any damage has occurred during shipping, immediately contact the transportation company that shipped them. Do not proceed with installation until the carrier's agent has inspected the damage.

Your components were packaged in specially designed cartons to help prevent damage. If reshipment is necessary, the components should be packaged in the original carton. If the original carton is not available, contact X-Rite to have replacements shipped to you.

## Packaging Drawings and Parts Lists

Check your package contents against your packing list and original order. A detailed packaging drawing and parts list is included in this manual as *Appendix B*.

## SYSTEM DESCRIPTION

The Auto-Tracking Spectrophotometer (ATS) provides both density measurements and colorimetric data, which are especially critical when printing with non-process inks. The ATS scans a color bar at a rate of 100mm a second using a 4.5mm color patch size. The ATS automatically locates and center itself on a color bar that is within 38mm of the paper's edge. The ATS Scanning Head is a 31-band, 45°/0° device that scans a spectral range of 400-700 nanometers.

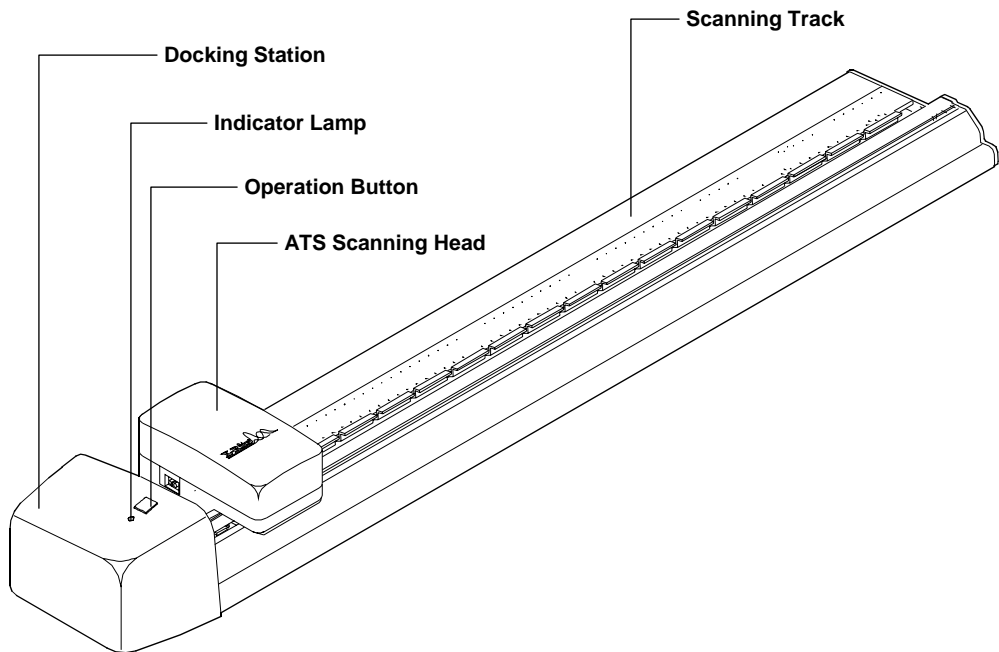

## Track and Docking Station

The press sheet is held securely to the track by a series of vacuum holes while the ATS Scanning Head measures the color bar. The Operation button can be used to activate a measurement sequence if desired.

The indicator light on the Docking Station illuminates three separate colors for various mode conditions:

- **Solid Green Light**—indicates that the scanning head is docked and ready for use.
- **Solid Yellow Light**— indicates that the scanning head is away from the docking station.
- **Solid Red Light**— indicates that an error or problem exists with the System.
- **Flashing Yellow Light**—indicates the unit powered up to take reading.
- **Flashing Red Light**—indicates there is a problem and the unit needs service.
- **Flashing Yellow & Green**—indicates System needs to be reset. Pressing and holding the Operation button for 5-seconds performs reset.

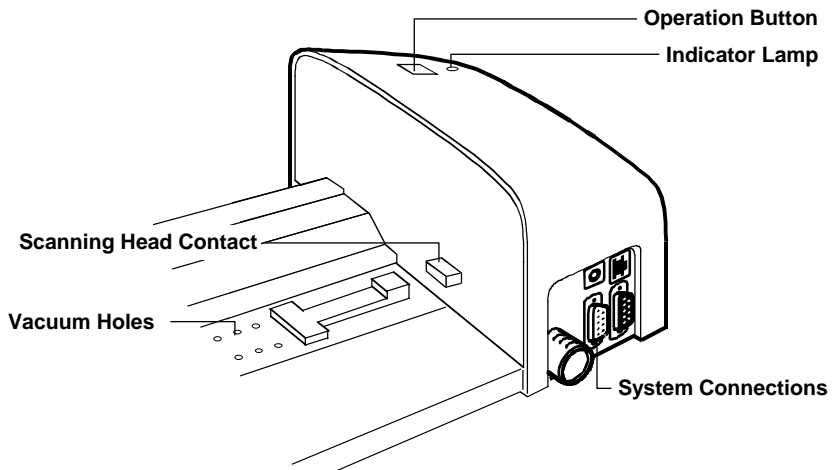

### **ATS Scanning Head**

The scanning head is a 31-band, 45°/0° device which scans a spectral range of 400-700 nanometers. The scanning head has 0.2DE repeatability on white. The instrument automatically locates and centers itself on a color bar.

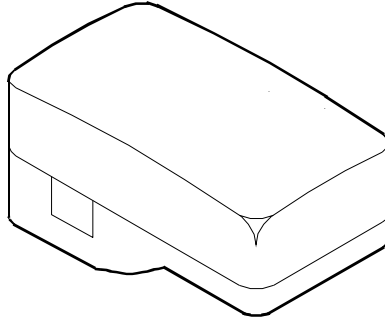

### **Handheld Spectrodensitometer**

The Handheld Spectrodensitometer supplied with your system allows you to take spot check measurements.

---

**NOTE:** It is recommended that you read the 500 Series Instrument Manual supplied with your system before using the handheld instrument.

---

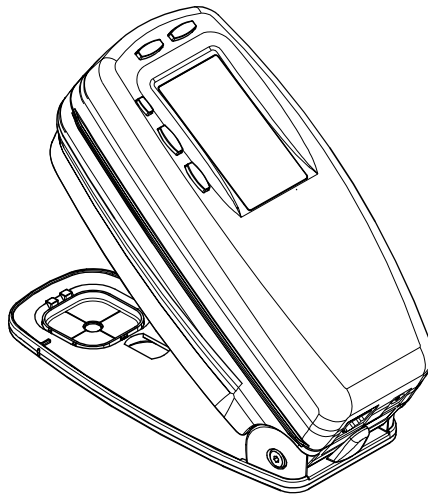



**Vacuum Pump**

A series of small holes located in the surface of the Track are used to hold the press sheet in place during a measurement. This is accomplished by the use of a Vacuum Pump. The Vacuum Pump is connected to the Docking Station allowing automatic activation during a measurement cycle.

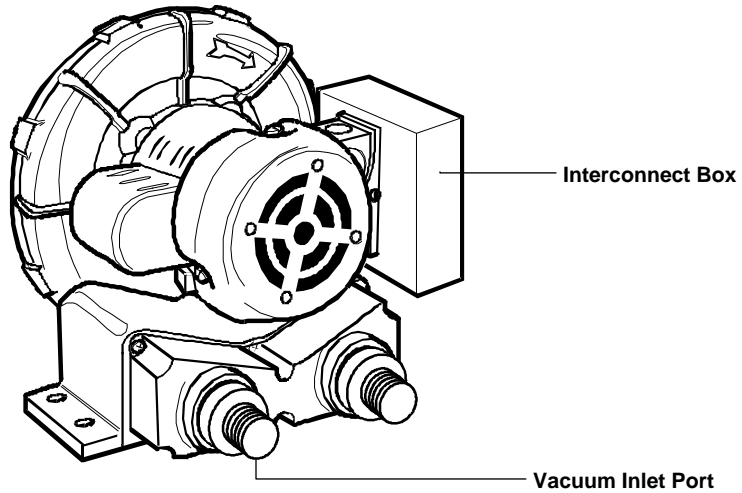

## INSTALLING THE ATS SCANNING HEAD

If the scanning is ever removed, follow the procedure below to reattach it to the track.

1. Position the Scanning Head Trolley approximately 12 inches from the Docking Station. This is accomplished by sliding the Trolley away from the Docking Station with your hand.
2. Position the Scanning Head over the Trolley and slide forward allowing the Holding Disks to insert into the Scanning Head.
3. Align the Trolley Thumbscrews with the Posts and Post Holes in the Scanning Head.
4. Loosely secure the thumbscrews to the Scanning Head. Alternately tighten until firmly seated.

---

**NOTE:** Scanning Head must be securely fastened to Trolley to allow proper operation of instrument.

---

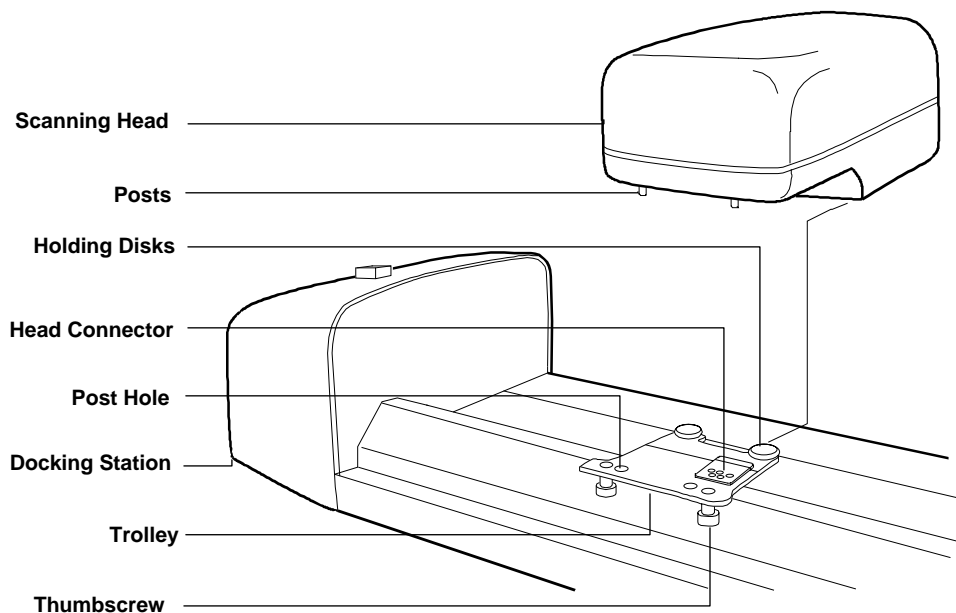

## SYSTEM CONNECTIONS

The System requires a few simple connections before operating. Connection procedures for the individual components are covered on the following pages.

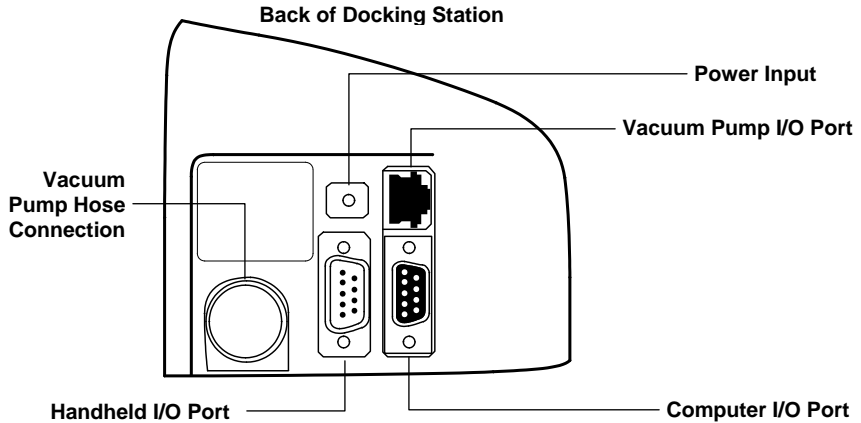

### Vacuum Pump Connections

1. Connect one end of Vacuum Hose to barbed adapter fitting labeled “IN” at rear of Vacuum Pump.
2. Connect other end of Vacuum Hose to barbed fitting in rear of the Docking Station.

---

**NOTE:** To obtain up to 15% more vacuum from the pump, remove the exhaust port barbed adapter.

---

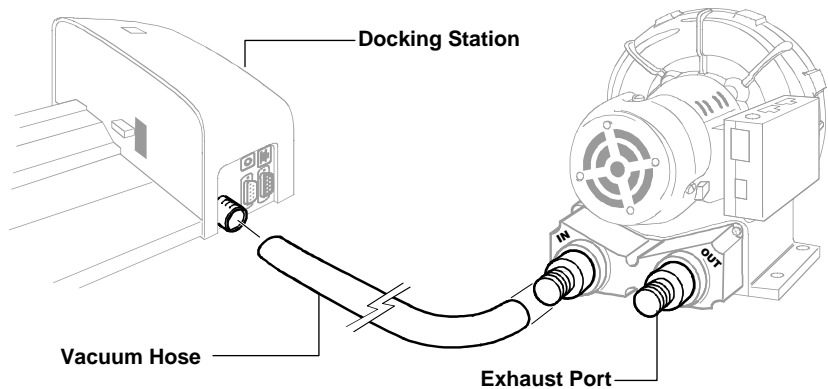

3. Make sure the Voltage Selection Switch—located below Line Cord Receptacle—has been set to the proper line voltage for your region.
4. Connect one end of I/O Interface Cable to the Vacuum Pump I/O Port on the Docking Station.
5. Connect other end of I/O Interface Cable to an I/O Port on the Vacuum Pump Connect Box (either port can be used).
6. Connect the Line Cord to the Vacuum Pump AC Cord Receptacle.
7. Plug Line Cord into AC wall receptacle.

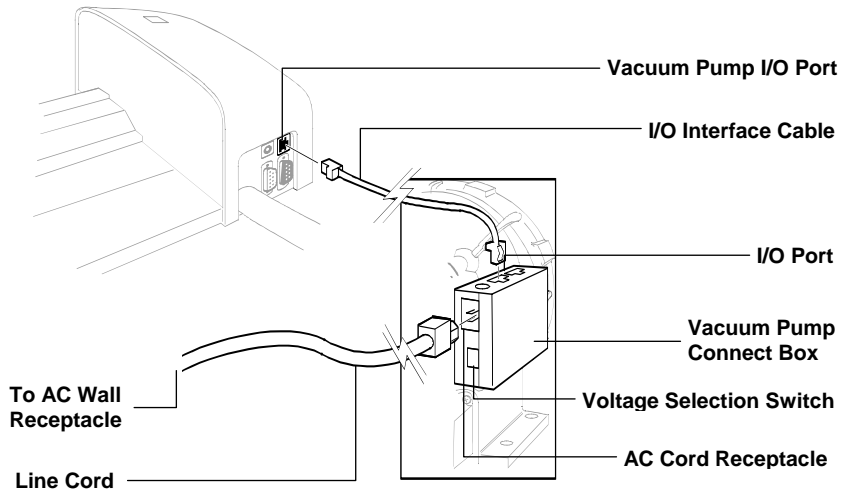

### Serial Port Interface Connection

1. Connect one end of the DB-9 Interface Cable to an available Serial Port on back of your computer. Secure with thumbscrews.
2. Connect opposite end of DB-9 Interface Cable to Serial I/O Port on back of Docking Station. Secure with Thumbscrews.

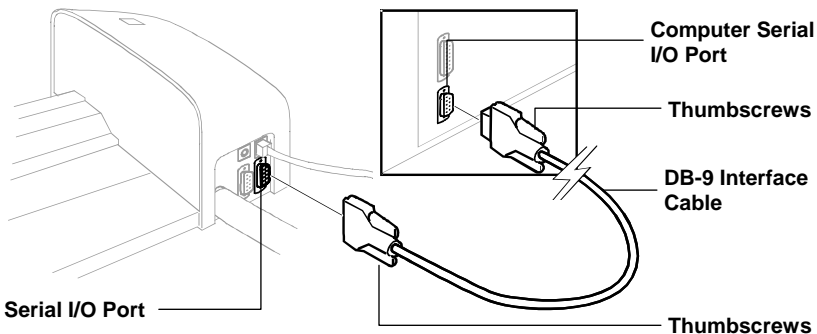

## Handheld Spectrodensitometer Connections

1. Attach the DB-9 adapter from the Interface Cable to the Handheld I/O Port on back of the Docking Station. Secure with Thumbscrews.

---

**NOTE:** If you are installing the Handheld Instrument on a 55" (139.7cm) or larger track, you will need to attach the additional DB-9 Interface Cable (supplied) between the Docking Station and Handheld Cable.

---

2. Insert the Modular Connector from the Interface Cable into the I/O Port on the back of the Handheld Instrument.

---

**CAUTION:** Use only the 12V Adapter (P/N SE30-77) to supply power to the Handheld Instrument.

---

3. Insert the 12V Adapter Jack into the Connector on the Handheld Cable.
4. Insert the Detachable Line Cord into the socket on the 12v Adapter.
5. Plug the Line Cord into an AC Wall Receptacle.
6. Verify the instrument's Serial Port Protocol is set to ICP. Refer to the Section Four in the Handheld Instrument Operator's Manual for procedure to verify protocol setting.

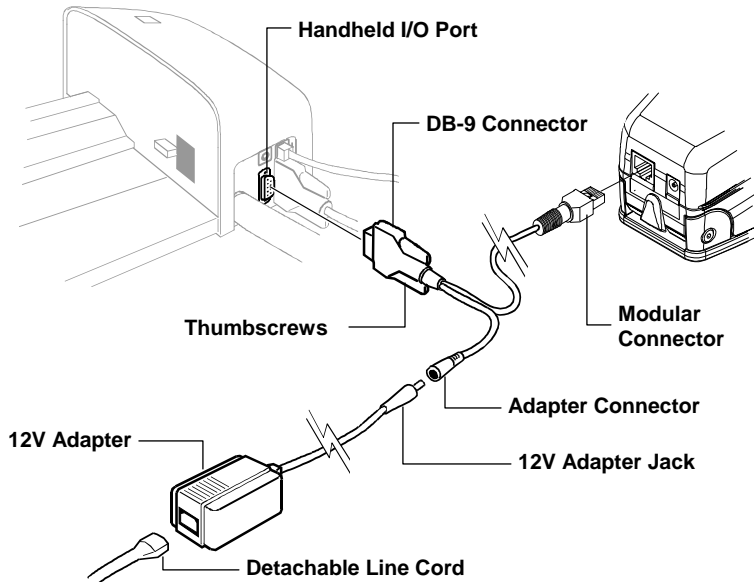

## Connecting Power

The ATS must be allowed to stabilize at room temperature before plugging the adapter into an AC wall receptacle.

---

**CAUTION: Use only the 24v Adapter (P/N ATS40-109) to supply power to the Docking Station.**

---

Power is applied to the Scanning System when the 24v Adapter is plugged into an AC wall receptacle. The System does not have an ON/OFF switch.

---

**NOTE: Scanning Head must be attached before power is applied.**

---

1. Insert the adapter jack of the 24v Adapter into the Power Input on back of Docking Station.
2. Insert the Detachable Line Cord into the socket on the 24v Adapter.
3. Plug the three prong plug from the Line Cord into an AC Wall Receptacle.

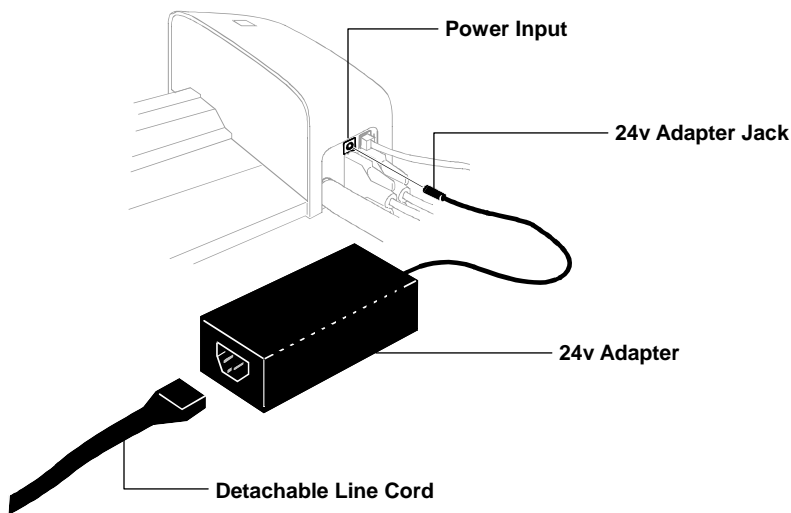

# Operating the System

---

Now that you have made all the necessary connections (and loaded your software) you are ready to operate your system. The heart of the Scanning Instrument is the compact, ATS Scanning Head. It moves along the track at approximately 150mm/sec. After a color bar is measured, the Scanning Head uploads the data to the computer via RS-232 communications.

This section covers sheet loading and alignment, and measurement procedures on both the Scanning System and Handheld. Refer to your Software On-line Help File for information regarding color bar selection and “Measure” type—Scanning or Handheld.

## Section Contents

- Sheet Loading and Alignment 2-1
- Taking a Measurement  
on the Scanning Instrument 2-3
- Taking a Measurement  
with the Handheld Instrument 2-4

## SHEET LOADING AND ALIGNMENT

Loading a press sheet onto the Scanning Instrument is fast and easy. There are no guides or clamps to adjust. The press sheet is loaded onto the track from the back over the plate that contains the vacuum holes. The press sheet is held in place by a vacuum that is created once the measurement sequence is started.

The sheet should be placed 90mm away from the docking station or centered on the track, and at least 60mm away from the end of the track.

To allow proper recognition and measurement of web ribbons, make sure there is at least a 5mm gap between each ribbon when reassembling on the track.

### Track Positioning

The press sheet must be positioned against the “sheet stops” that run along the back edge of the vacuum plate. The color bar on the sheet cannot be over 38mm from the paper’s edge.

In the event that a color bar is not properly aligned on a press sheet (this is recognized during a job setup), the scanning system takes corrective action by automatically adjusting the ATS scanning head (the scanning head will track linearly from the first patch to the last patch). This ensures all color patches are measured accurately.

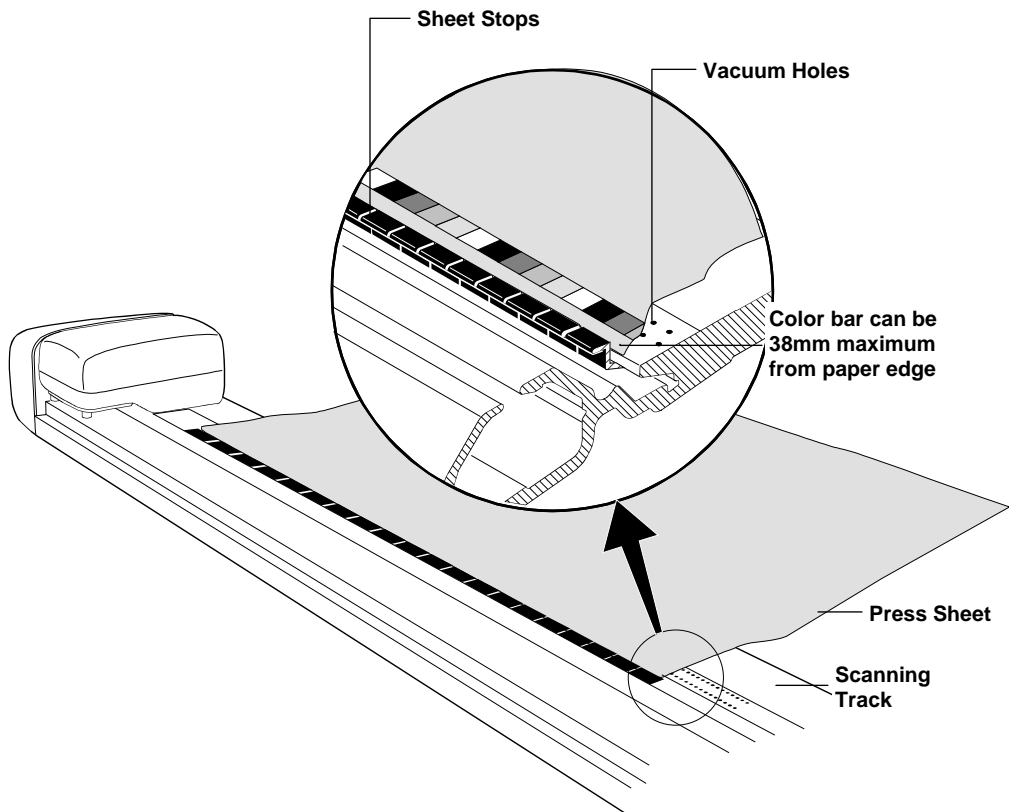



## Performing a recognition/measurement on the scanning instrument

After the press sheet is properly positioned on the track, you are ready to perform a color bar recognition/measurement. The sequence is started in one of two ways: by selecting the recognition/measurement function from the Software, or by pressing the Operation button located on top of the Docking Station.

Once a scan is set in motion, the vacuum pump activates and the “green” light on the station changes to “yellow,” indicating a scan is in progress. The scan head travels the entire length of the sheet before returning to the docking station. If an additional color bar is located on the opposite edge of the sheet, the software will inform you when to rotate the sheet for measurement. Refer to your software documentation for additional information.

If a problem is encountered during a measurement, the scanning head immediately returns to the docking station. View your computer monitor to see if an error message is displayed. If no message is displayed, try to rescan sheet; if a problem still occurs, refer to the Troubleshooting section in this manual.

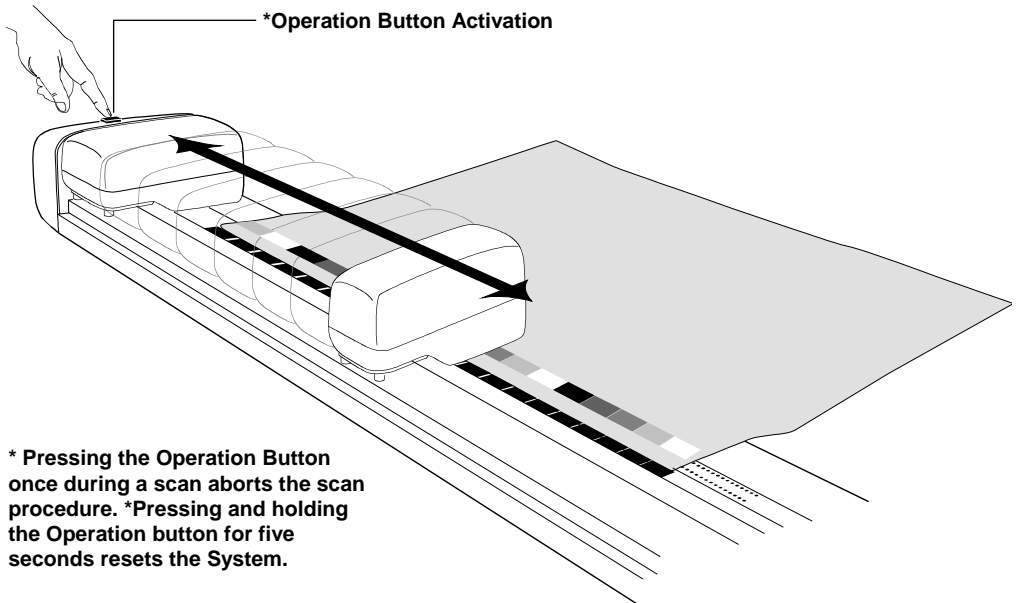

## TAKING A MEASUREMENT WITH THE HANDHELD INSTRUMENT

The Handheld instrument can be used to measure ink colors and make spot check measurements as needed. The shoe of the instrument should be able to rest flat and steady on the sample area.

- Place the instrument's target window opening on the color patch or image area to measure. The opening should be completely filled with the sample color.
- Lower the instrument down to the target window and hold closed.

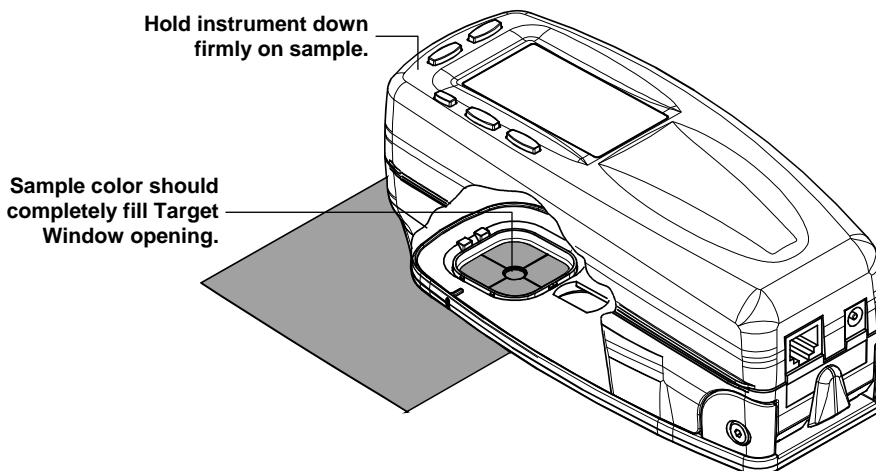

- When measurement is complete the results are instantaneously displayed on the computer.

If the instrument is moved during measurement or is not held closed for the entire measurement, your computer will beep twice and no data be displayed. Simply take another measurement.

# Calibration

---

Regular calibration of the Scanning and Handheld instrument is important to maintain accurate and consistent measurement data. The Software calls for a calibration whenever it is required. Manual calibration can also be selected if desired.

This section covers calibration. Refer to your Software On-line Help file for procedures to activate and set various calibration parameters.

## Section Contents

- Calibrating the Scanning Instrument 3-1
- Calibrating the Handheld Instrument 3-2

## CALIBRATING THE SCANNING INSTRUMENT

Calibrating the Scanning Instrument is virtually automatic there is no calibration reference positioning required. Calibration Disks are a permanent part of the Track assembly, located near the Docking Station. A retractable cover protects the Disks when the Scanning Head is away from the Docking Station. The Scanning Head automatically calibrates to the disks when required or when initiated by the user.

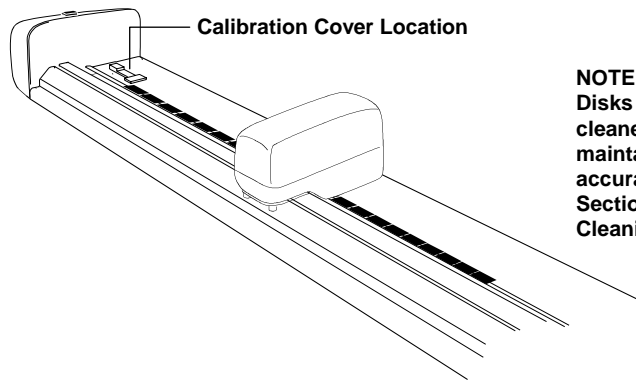

**NOTE: The Calibration Disks should be cleaned periodically to maintain calibration accuracy. Refer to Section Four, General Cleaning.**

## CALIBRATING THE HANDHELD INSTRUMENT

---

**NOTE:** Make sure calibration reference is clean before continuing with calibration procedure.

---

- Place Calibration Standard on a steady surface and position your instrument on it. The instrument fits snugly with the target window opening centered over the white ceramic disk.

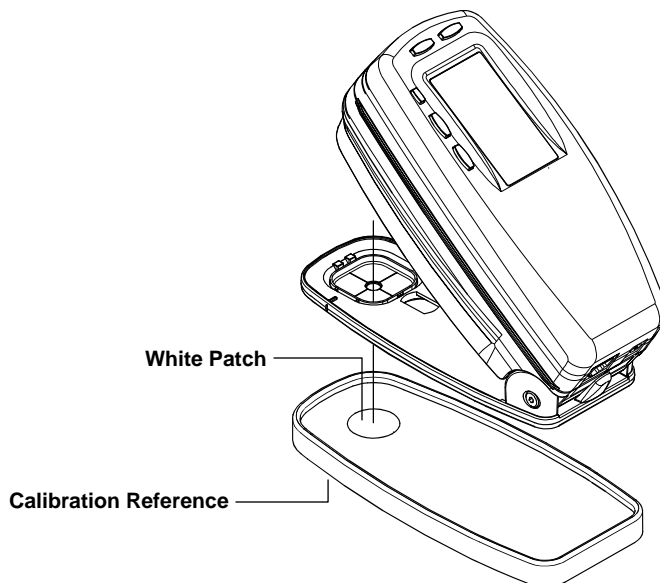

- Lower the instrument to the shoe to take a measurement. Your computer informs you when the measurement is complete.

---

**NOTE:** If the instrument calls for a Full Calibration (white and black), refer to the Instrument Operator's Manual, Section Four for Full Calibration procedure. Refer to Section Three in Instrument Operator's Manual for additional information on Calibration.

---

### Cleaning the Handheld Calibration Reference

When not in use, store the calibration reference in a dry, dust free area, away from direct exposure to light.

The calibration reference is dramatically affected by smudge marks, dust, and finger prints. Gently clean the reference with a dry, lint-free cloth.

# General Maintenance

---

This section will cover the maintenance procedures for the system.

## Section Contents

- Repair Information ..... 4-1
- Overview ..... 4-1
- Scanning Head ..... 4-1
- Scanning Track ..... 4-3
- Cleaning the Calibration Disks..... 4-4

## REPAIR INFORMATION

Your ATS System is covered by a three-year limited warranty and should be referred to the factory for repairs within the warranty period. Attempts to make repairs within this time frame may void the warranty.

X-Rite provides a factory repair service to their customers. Because of the complexity of the circuitry, all repairs should be referred to the factory.

X-Rite will repair any ATS System past warranty. Shipping cost to the factory shall be paid by the customer, and the instrument shall be submitted in the original carton as a complete, unaltered unit.

## OVERVIEW

The System requires little preventative maintenance to achieve years of reliable operation. However, to protect your investment and maintain measurement accuracy, a few simple cleaning procedures should be performed.

## SCANNING HEAD

**NOTE:** DO NOT use any solvents or harsh cleaners of any kind.

**NOTE:** DO NOT move the trolley up and down the track manually without the scanning head attached.

In the course of normal use, spray powder, paper dust, and other airborne contaminants will likely enter the instrument's optics. This can eventually reduce the sensitivity of the instrument and may lead to calibration errors. Follow the steps below to clean the optical components.

### **Cleaning (1 to 2 times a month)**

1. Obtain a source of clean, dry, compressed air. This air should be of the quality used to clean delicate camera lenses.
2. Remove the scanning head from the track. To do this:
  - Disconnect power from the track.
  - Gently slide the head away from the docking station.
  - Loosen the two thumbscrews that lock the head to its trolley.
  - Gently free the head from the trolley.
3. Being careful to hold the compressed air source upright, blow short, gentle bursts of compressed air directly into the instrument's aperture. Be careful to ensure the compressed air nozzle is approximately 10mm away from the optics.

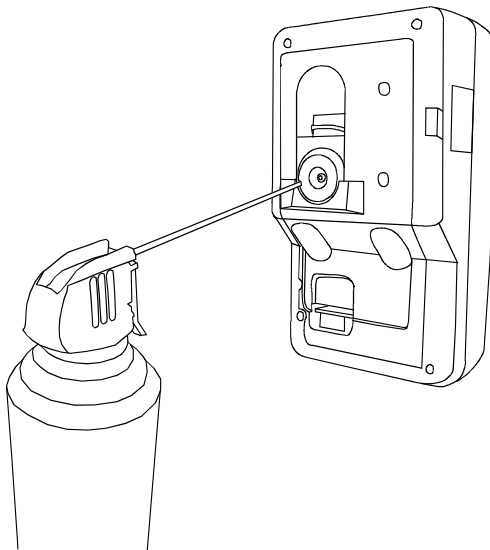

4. Re-attach the scanning head to the trolley. To do this:
  - Carefully align the head back onto the trolley. Take care to ensure that the head is properly seated on the alignment pins.
  - Tighten the thumbscrews that secure the head to the trolley. Gently wiggle the head as you tighten the screws to ensure that the head is fully seated.
  - Slowly slide the head back into the docking station.
  - Re-connect the power to the track.

5. Note that the process of cleaning the optics will affect the instrument's sensitivity as dust and powder will no longer block the optical path. It is essential that the head be fully calibrated following the cleaning process.
6. The exterior of the scanning head and docking station can be wiped clean with a lint-free cloth dampened in water or a mild cleaner.

**Maintenance**

1. Replace the five (5) Read Head Pogos if they display any signs of wear or discoloration.
2. On newer read heads, replace the Paper Stop Push Plate if anodize is broke or worn through.

**SCANNING TRACK**

**NOTE:** DO NOT reverse the intake/exhaust port on the vacuum to blow out the track vacuum chamber. This will force any dust inside the track into the read head optics.

**NOTE:** DO NOT use any solvents or harsh cleaners of any kind.

**NOTE:** DO NOT use any type of lubrication (oil) on any part of the system.

**Cleaning (1 to 2 time a month)**

1. The exterior of the docking station can be wiped clean with a lint-free cloth dampened in water or a mild cleaner.
2. The track can be wiped clean with a lint-free cloth dampened in glass cleaner. When cleaning the track, make sure to clean the entire track. This includes the portion of the track that resides under the reading head when it is in its docked position. You can simply slide the head over when cleaning is required.
3. Inside of track assembly – use compressed air to remove all print dust.

**Maintenance**

- Replace the following items at 500,000 scans.
- Trolley bearings and wheels
- Power cable
- End plate bearings (both ends)
- Nut on drive screw
- Station home sensor pogos

Usage Approximation		
Usage	Scans per day	Year to reach 500,000
Heavy	300	4.5
Medium	150	9.0
Light	75	13.5

## CLEANING THE SCANNING CALIBRATION DISKS

On a daily basis you may need to clean the Calibration Disks located in the Track. This is a relatively easy procedure requiring only a few minutes of time.

1. Carefully slide the Scanning Head away from the Docking Station.
2. Pull Calibration Cover towards the Docking Station to expose the Disks.
3. Clean Disks with a cotton swab or lint-free cloth.
4. Blow off Disks with compressed air.
5. Blow out under the Calibration Cover with compressed air.
4. Carefully release Calibration Cover and slide Scanning Head back against Docking Station.

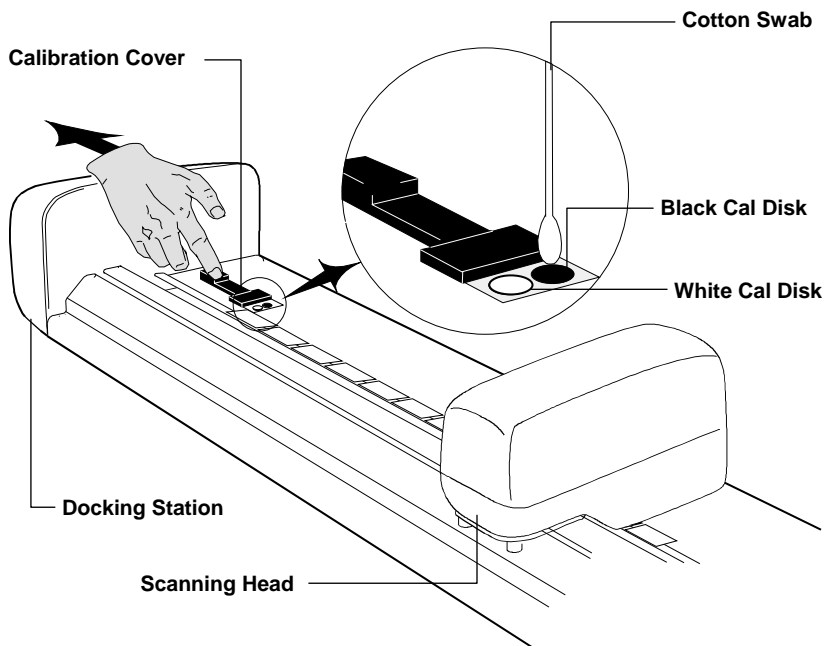



# Troubleshooting Tips

---

The Software constantly scans the system looking for any type of problems that may arise. When a problem is discovered, the Software will display an error message on the computer monitor, pinpointing the problem area. A list of “hardware” related error messages is listed below.

## Error Messages and Reason/Solution

Error Messages	Reason/Solution
<b>Docking Failure</b>	Measurement was initiated—scanning head returned and docked—but the data was not transmitted from the scanning head. Check for loose cabling.
<b>Lamp Burned Out</b> <b>Lamp Intensity Low</b> <b>Lamp Voltage High</b> <b>Lamp Voltage Low</b> <b>Motor Jammed</b> <b>Motor Too Fast</b>	Scanning head needs service. Contact X-Rite, Incorporated.
<b>Scanning Head not at Docking Station</b>	Measurement was initiated but the scanning head was not at the docking station. Slide head against docking station.

Other problems that may occur and not be detected by Software are as follows.

### **Problems and Reason/Solution**

<b>Problems</b>	<b>Reason/Solution</b>
Scanning head will not activated when measurement cycle is performed by the Software.	Check to see if Software displayed any error message.  Check for proper connection of interface cables and adapters between computer and Scanning System.
Measurements incorrect or not repeatable.	Scanning System needs calibration.  Scanning head need service. Contract X-Rite, Incorporated.
Handheld Instrument will not function with the Software.	Check for proper connection of interface cable between Handheld Instrument and Scanning System.  Instrument serial port protocol is not set to "ICP." Refer to Section Four in the Instrument Operator's Manual for procedure to set Protocol.

# Technical Specifications

---

<b>Measurement Geometry</b>	45°/0° per ANSI PH2.17
<b>Light Source</b>	Gas Pressure @ 2850°K
<b>Spectral Sensor</b>	DRS Technology (31pt)
<b>Spectral Range</b>	400nm - 700nm
<b>Reflectance Range</b>	0 - 200% R
<b>Density Range</b>	0 - 2.5D
<b>Repeatability on White</b>	0.2 DE max. ±0.01 Density max.
<b>Density Reproducibility</b>	±0.02 Density @ 1.5 Density
<b>Calibration</b>	Automatic
<b>Scan Spot Size</b> (total Scanned spot)	3.0mm x 3.5mm min.
<b>Patch Width</b> (along scan path)	3.8mm min.
<b>Patch Height</b>	5.0mm min.
<b>Paper Thickness</b>	1.5mm max.
<b>Scanning Rate</b>	150mm/sec. (6.8 mm patch) 100mm/sec. (4.8 mm patch)
<b>Scanning Width Available</b>	1,016mm (40 inches) standard <i>Other lengths available</i>
<b>Color Bar Location</b>	Paper Edge to 38mm from edge.
<b>Color Bar Alignment</b>	Automatic centering of measurement on color bar. Paper set against stop.
<b>Color Bar Quantity</b>	Multiple Rows
<b>Paper Hold Down</b>	Vacuum activated with measurement command.
<b>Power Required</b>	110/240VAC, 50-60Hz, 4/2A.

Specifications and design subject to change without notice.



APPENDIX B

# Parts List and Packaging Drawing

42	1	1	1	1	1	L4-038	TRAINING BROCHURE
41	1	1	1	1	1	SD01-L7-192	COLOR BAR STRIP
40	-	-	-	-	-	NOT USED	
39	1	1	1	1	1	ATS40-597	SCANNING HEAD PACKING STRIP
38	1	1	1	1	1	SD43-ATS40-13	ATTENTION LABEL
37	1	1	1	1	1	SD200-ATS40-09	FOAM PAD
36	1	1	1	1	1	SD117-10	FLEXIBLE SCALE
35	-	-	-	-	-	NOT USED	
34	1	1	1	1	1	SD01-04GE	WARRENTY REGISTRATION (GERMAN)
33	1	1	1	1	1	SD01-04FR	WARRENTY REGISTRATION (FRENCH)
32	1	1	1	1	1	SD33-08	LINE CORD, 230V
31	-	-	-	-	-	NOT USED	
30	-	-	-	-	-	NOT USED	
29	-	-	-	-	-	NOT USED	
28	1	1	1	1	1	ATS40-192	VACUUM MOTOR ASSEMBLY
27	1	1	1	1	1	SD01-10	IMPORTANT NOTICE
26	1	1	1	1	1	1223-703	QUICK START INSTRUCTIONS
25	1	1	1	1	1	SD01-04	WARRANTY REGISTRATION
24	1	1	1	1	1	ATS40-500	OPERATION MANUAL
23	1	1	1	1	1	SD01-39	CERTIFICATE OF CALIBRATION
22	1	1	1	1	1	SD68-11	ENVELOPE
21	1	1	1	1	1	SD200-DTP22-10	CARTON
20	-	-	-	-	-	NOT USED	
19	-	-	-	-	-	NOT USED	
18	2	2	2	2	2	SD200-ATS40-08	FOAM SPACER
17	-	-	-	-	-	NOT USED	
16	1	1	1	1	1	ATS40-109	POWER SUPPLY ASSEMBLY
15	1	1	1	1	1	SE108-12-01	CABLE ASSEMBLY
14	3	3	3	3	3	SD65-13	PLASTIC BAG
13	1	1	1	1	1	SD33-07	LINE CORD, 115v
12	1	1	1	1	1	SM309-06	PLASTIC SHEET 36" x 60"
11	-	-	-	-	-	NOT USED	
10	1	1	1	1	1	ATS28-18	BASE CLAMP
9	-	-	-	-	-	NOT USED	
8	-	-	-	-	-	NOT USED	
7	-	1	-	1	-	530/LP/ATS	SPECTRODENSITOMETER
	-	-	-	-	1	530P/ATS	SPECTRODENSITOMETER
	1	-	1	-	-	530S/ATS	SPECTRODENSITOMETER
6	-	-	-	-	-	NOT USED	
5	-	-	-	-	-	NOT USED	
	-	-	-	-	1	ATS40S-00-02	ATS40S INSTRUMENT ASSEMBLY
	-	-	-	1	-	ATS40MLP-00-02	ATS40MLP INSTRUMENT ASSEMBLY
4	-	-	1	-	-	ATS40M-00-02	ATS40M INSTRUMENT ASSEMBLY
	-	1	-	-	-	ATS40LP-00-02	ATS40LP INSTRUMENT ASSEMBLY
	1	-	-	-	-	ATS40-00-02	ATS40 INSTRUMENT ASSEMBLY
3	-	-	-	-	-	NOT USED	
2	AR	AR	AR	AR	AR	SM02-06	PLASTIC BANDING, 1/2"
1	1	1	1	1	1	SD200-ATS40	PACKAGING SYSTEM
ITEM	QTY ATS40	QTY ATS40 LP	QTY ATS40 M	QTY ATS40 MLP	QTY ATS40 S	PART NUMBER	DESCRIPTION
<b>ATS40 MODEL PARTS LIST</b>							

# APPENDIX B

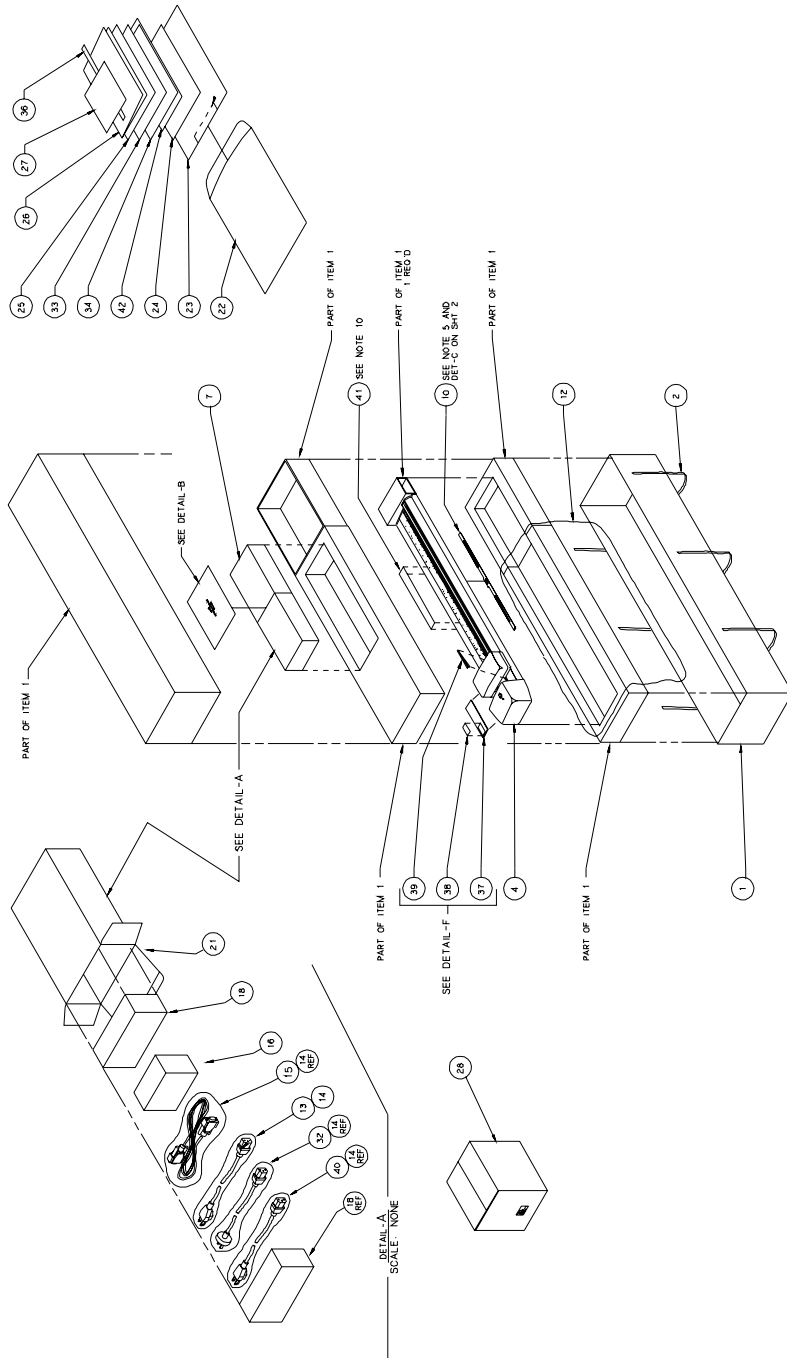





**X-RITE WORLD HEADQUARTERS**

Grandville, Michigan USA  
www.xrite.com  
1-888-826-3059  
FAX 1-888-826-3061 or 616-534-0726  
International  
1-888-826-3039 or 616-534-7663  
FAX 616-534-0723

**X-RITE ITALY S.R.L.**

Origgio (VA), Italy  
(39) 02-967-34266  
FAX (39) 02-967-30681

**X-RITE LATIN AMERICA**

Hollywood, Florida USA  
954-927-4979  
FAX 954-927-4979

**X-RITE GmbH**

Köln, Germany  
(49) 2203-91450  
FAX (49) 2203-914519  
Vyskov, Czech Republic  
(00) 420 517-320-331  
FAX (00) 420 517-320-335

**X-RITE LTD.**

Poynton, Cheshire  
United Kingdom  
44 (0) 1625 871100  
FAX 44 (0) 1625 871444

**X-RITE INTERNATIONAL  
TRADING LIMITED**

Shanghai, PR China  
86-21-6427-2426  
FAX 86-21-6427-5816

**X-RITE MEDITERRANEE**

Massy, France  
33 1-6953-6620  
FAX 33 1-6953-0052

**X-RITE IBERICA**

Barcelona, Spain  
34 93 567 70 73  
FAX 34 93 567 70 78

**X-RITE ASIA PACIFIC LTD.**

Quarry Bay, Hong Kong  
(852) 2-568-6283  
FAX (852) 2-885-8610

**X-RITE K.K.**

Tokyo, Japan  
81-3-5439-5971  
FAX 81-3-5439-5972